

SOLUTIONS FOR HANDLING RESIDUAL WASTE

The **Biodrum equipment of Bianna Recycling** is a simple type of technology, which is strong and reliable and with which a reduction in volume and humidity is obtained for residual waste, improving the separation and recovery of different fractions of material that has been processed. The field of application includes practically all of the process areas of municipal waste, like the selection, incineration, composting, anaerobic digestion or their disposal in landfill sites.

The Biodrum is mainly made up of a horizontal steel cylinder where the waste is standardised, dispersed and partially degraded. The output material can be subsequently processed obtaining a fraction of fine elements that contain, on the whole, organic material, paper, cellulose and a resultant product with a high calorific value (Solid Recovered Fuels SRFs).

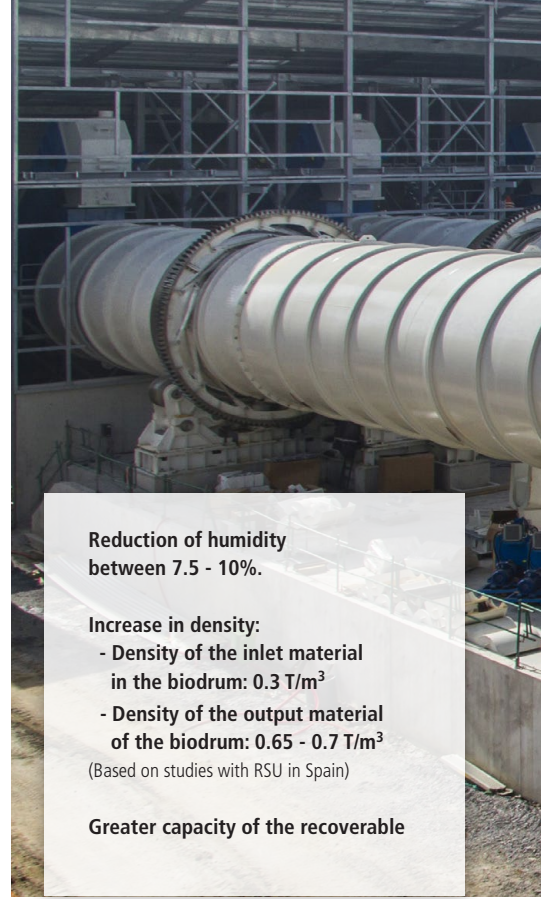

Reduction of humidity between 7.5 - 10%.

Increase in density:

- Density of the inlet material in the biodrum: 0.3 T/m^3
- Density of the output material of the biodrum: $0.65 - 0.7 \text{ T/m}^3$

(Based on studies with RSU in Spain)

Greater capacity of the recoverable

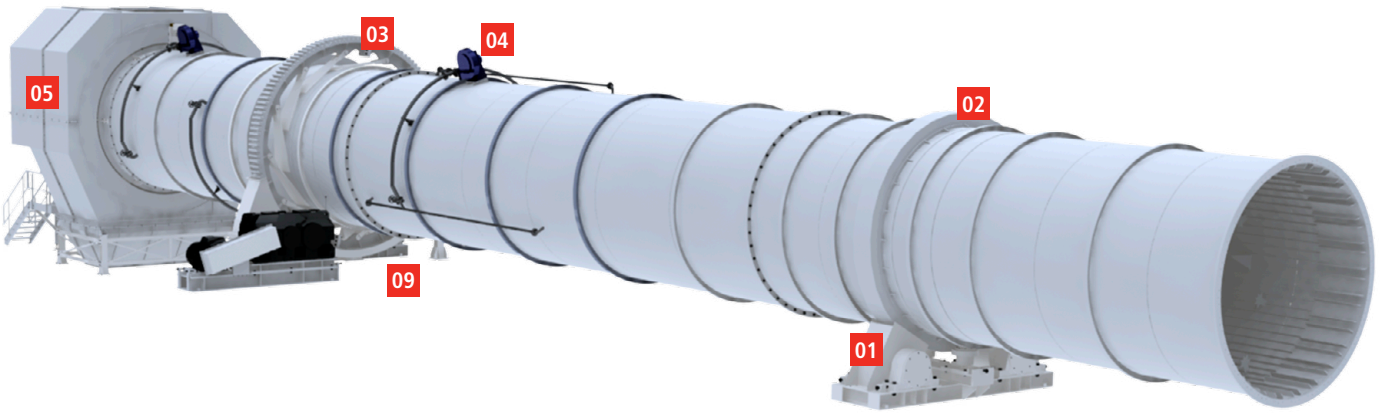

MAIN PARTS

STANDARD	
Support wheels	01
Runner ring	02
Toothed crown	03
Fans	04
Discharge hopper	05
Blades to open the material	06
Internal profiles	07
Maintenance door	08
Lifting cylinder	09



OPTIONAL
Unloading bypass
Maintenance trolley
Hydraulic power supply



CHARACTERISTICS

It is an optimum technology for the production of Solid Recovered Fuels (SRFs)

It uses a smooth breaking up process that mainly affects the fraction of biodegradable waste.

It produces a reduction in the volume as a result of the increase of the apparent density

It produces a reduction of the mass as a result of lower humidity in organic material

Reliability: availability >99%

Power supply system with hopper or piston.

Possibility to control the speed of the cylinder and the percentage that controls how much the output opening for material is.

Possibility to install a classification area at the end of the cylinder.

APPLICATIONS

Raw materials for the installations to convert waste into energy.

Recycling of materials with added value.

Reduction of the volume and mass in the transfer stations and controlled dumping.

Anaerobic digestion and/or composting.

DESCRIPTION OF THE PROCESS

A Biodrum can process up to 20 tons of waste an hour, with a residence time between 2 and 3 days when continually running. The rotation of the machine, between 0.75 and 2 revs per minute, includes the standardising and breaking up of the material due to its friction and wearing down. Inside the Biodrum, the possibility to add water or leachates benefits the aerobic degradation of the organic material, obtaining a reduction in terms of volume and mass of the biodegradable compounds.

MODELS

Type	Inside diameter	Total length	Power	Weight	Capacity
	mm	mm	kW	Kg	t / day
BD2,5/25	2,500	25,800	45	49,000	23
BD3,0/30	3,000	29,300	55	52,000	40
BD3,6/32	3,660	31,900	90	100,000	60
BD3,9/35	3,880	35,300	145	160,000	70
BD4,2/50	4,250	48,000	250	270,000	130

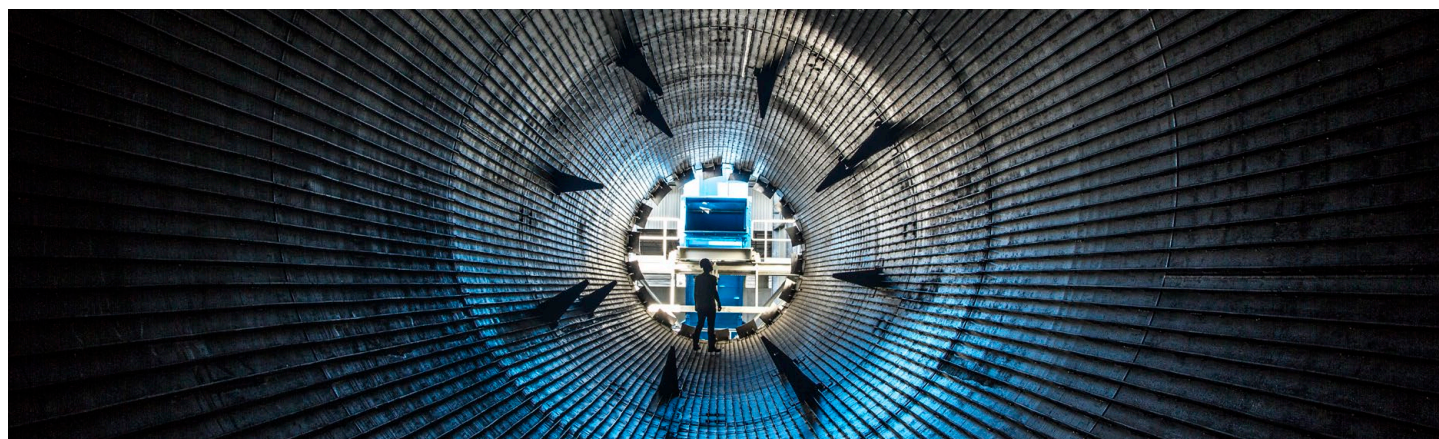

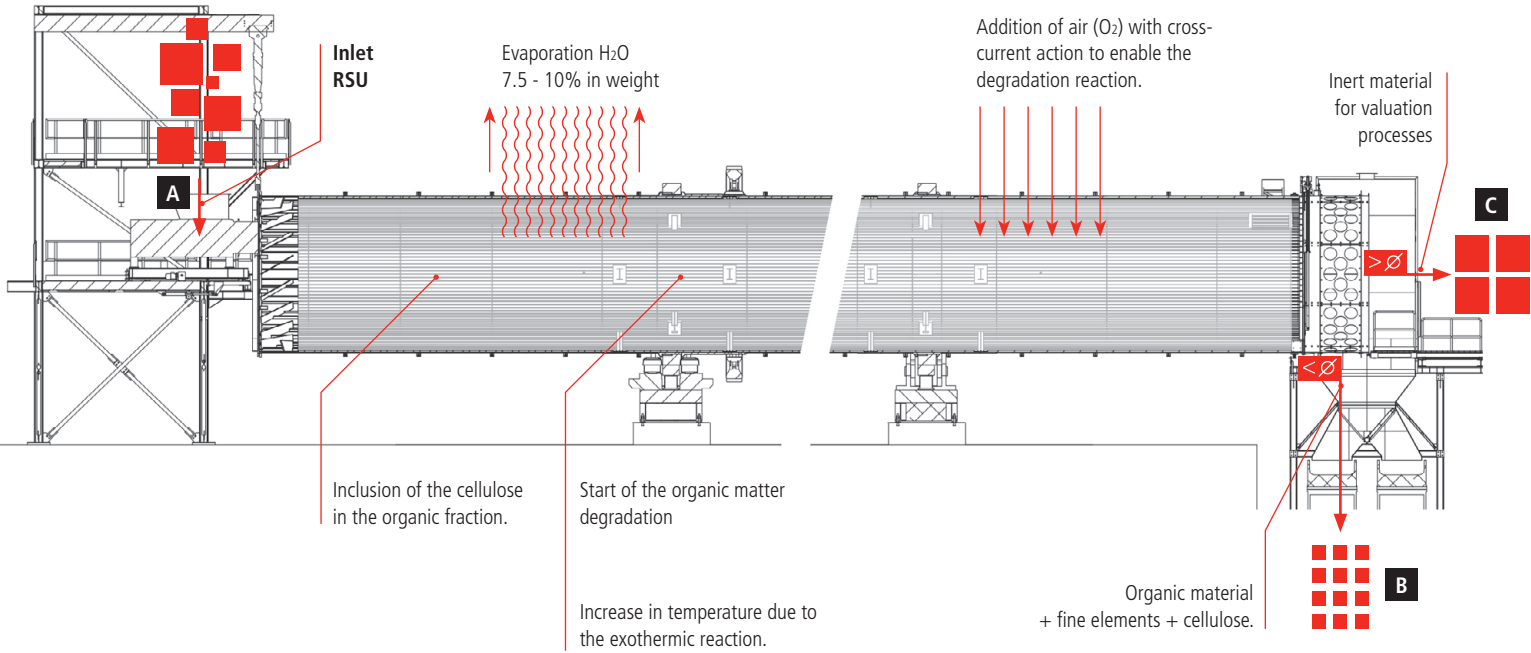

biannarecycling.com

+34 902 104 266 • info@biannarecycling.com

Advanced Recycling Technologies